

Identifying Your Rear Road Hub

American Classic Rear RD205: 17mm Axle (Current Style) or 15mm Axle (Old Style).

If your rear road hub does not appear here you may have a Victory Hub. Please see: Identifying Your Rear Victory Hub.

17mm Hub (Current Style)

This hub uses four **6803 C3** fully sealed bearings. Two in the hub shell and two in the free hub body.

Stainless steel bearings standard.
Ceramic bearings are available as an upgrade.

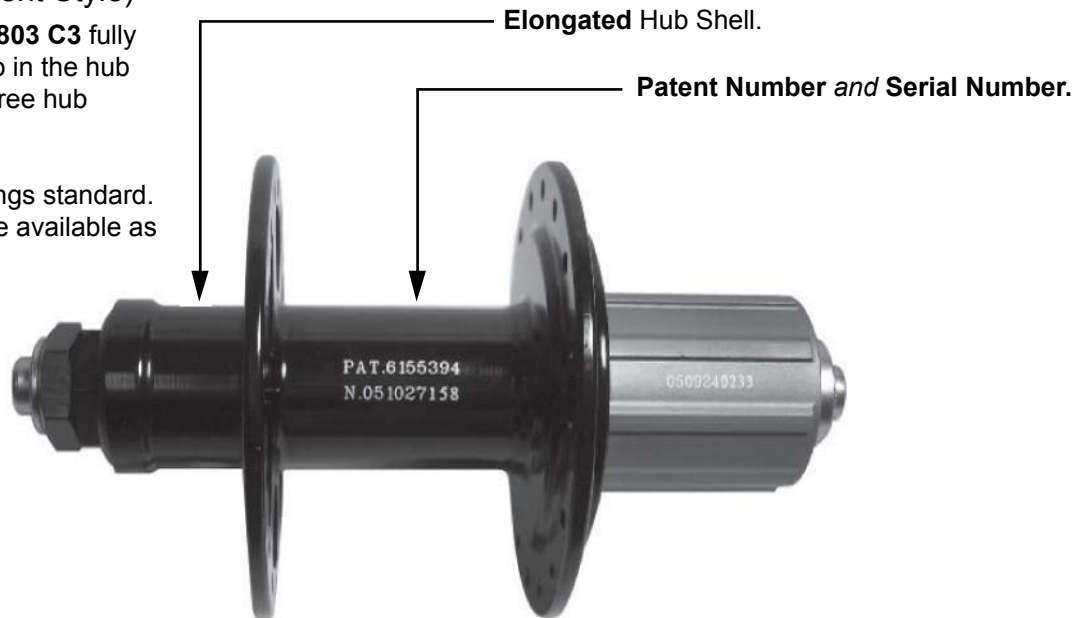

15mm Hub (Old Style)

This hub uses four 15267 fully sealed bearings. Two in the hub shell and two in the free hub body.

Ceramic bearing upgrade is not available for 15mm hubs.

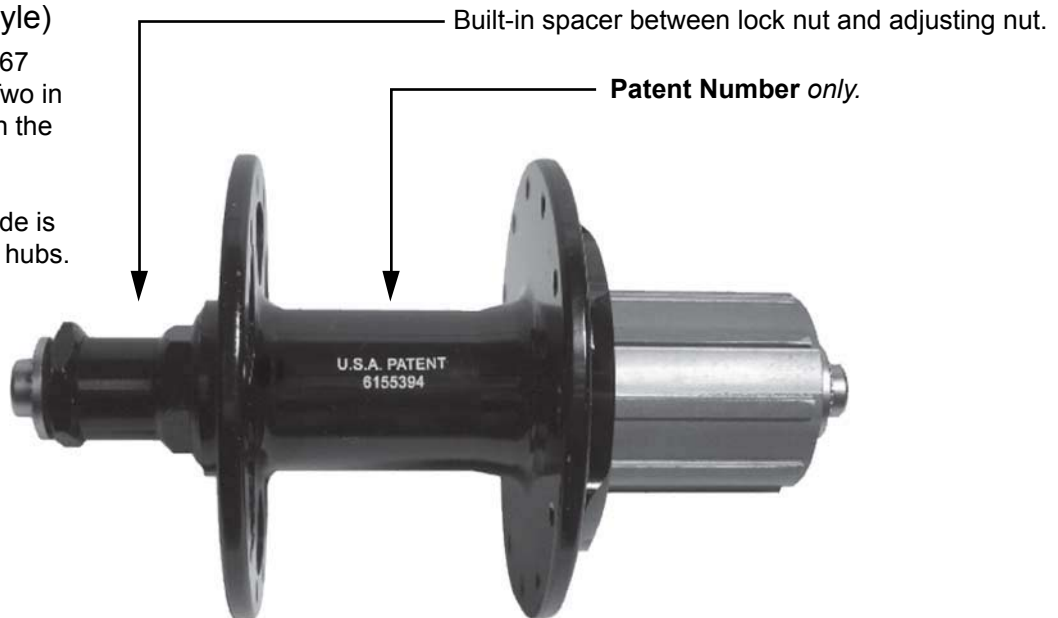

If you have identified your hub as being a 15mm hub, please continue onto the next page to find out if the cassette body or hub is upgradable. Not all 15mm cassette bodies are able to be upgraded. 15mm hubs are NOT Campagnolo 11-speed compatible.

15mm Hub - Can I Upgrade?

15mm Hub (Old Style) Cassette Body Identification.

If you have identified your hub as being a 15mm hub, please continue on this page to find out if the cassette body or hub can be upgraded with new parts. If your hub has any of the following features, it can not be upgraded with new parts and it is discontinued and out of stock.

3-Pin Style Cassette Bodies:

These hubs and parts have been discontinued and are out of stock.

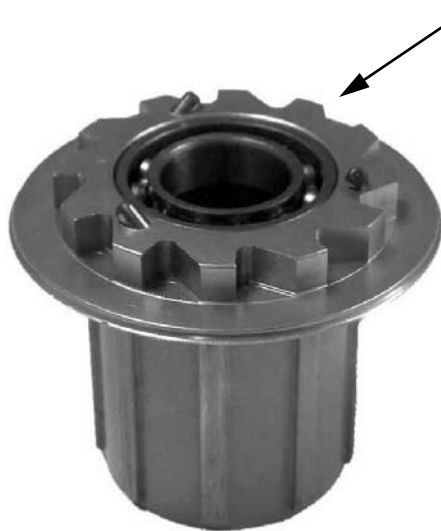

12 Tooth 3-Pin Style
15mm cassette body.

Notice:
The cassette body and
large aluminum seal
protecting the pawls is
one piece.

**CAN NOT
BE UPGRADED.**



24 Tooth 3-Pin Style
15mm cassette body.

**CAN NOT
BE UPGRADED.**

Grease Port Hubs:

If your hub has a grease port, it can not be upgraded with new parts and it is discontinued and out of stock.

Grease Port

A grease port is located in the center of the hub, between the flanges and spokes.

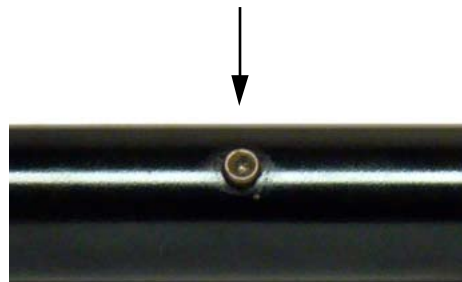

**CAN NOT
BE UPGRADED.**

These hubs have been discontinued and are out of stock.